

4" HYDRAULIC SUBMERSIBLE SHREDDER PUMP

MODEL S4SHR

4" (100 mm) Discharge

The S4SHR is designed to continuously rip and shear solids with a 360° shredding action. Great for municipal, industrial, agricultural and institutional waste applications. A guide rail assembly is available for stationary applications.



FEATURES

- Open-Vane Shredder Impeller with Tungsten Carbide Cutting Tip
- Hardened Macerator Suction Plate
- Oil Lubricated Seals (can run dry)
- Variable Speed hydraulic drive to 2000 rpm
- Versions for Portable or Fixed Installations
- Safe Hydraulic Drive can be used where electric power is hazardous or impractical
- Dependable gear type hydraulic motor
- Operates with our HT15 to HT25 power units or other hydraulic power sources capable of flows of 10 - 15 GPM

SPECIFICATIONS

WEIGHT:.....	254 lbs. (115 kg)
HEIGHT:.....	28" (71 cm)
WIDTH (w/Discharge elbow):.....	29 1/2" (75 cm)
(Across Volute).....	16 3/4" (43 cm)
DISCHARGE:.....	4" ANSI Flange or 4" NPT(F)
SOLIDS HANDLING:.....	3 1/2" (89 mm)
HOSE PORTS:.....	3/4" (-12) SAE(F)
PUMP BODY:.....	Ductile Iron
IMPELLER:.....	Ductile Iron
SHREDDER BLADE:.....	Tungsten Carbide
SHAFT:.....	Stainless Steel
SHAFT SEAL:.....	(Upper) Carbon/Ceramic (Lower) Silicon Carbide
ELASTOMERS:.....	Buna N
HYDRAULIC OIL:.....	214-320 s.s.u. @ 100°F (64°C)
INPUT FLOW:.....	Max. 15 GPM (57 LPM)
OPERATING PRESSURE:.....	Max. 2600 PSI (177 Bar)
POWER SOURCE:.....	Any Open Center Hydraulic System

D0516

Specifications are subject to change without notice

Model S4SHR Overall Dimensions

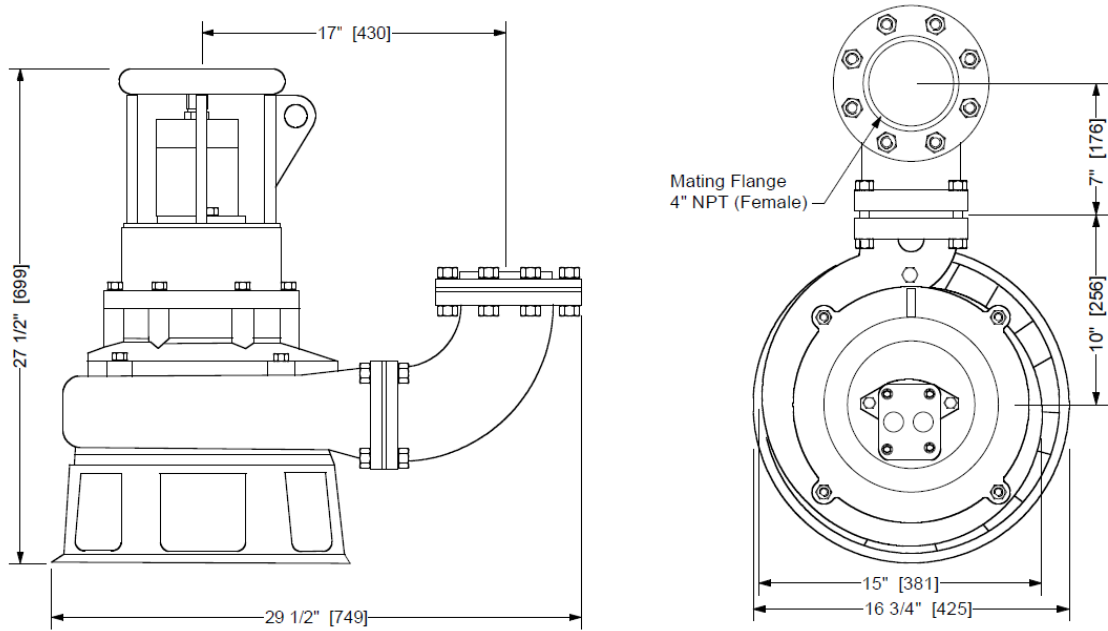

S4SHR Typical Performance

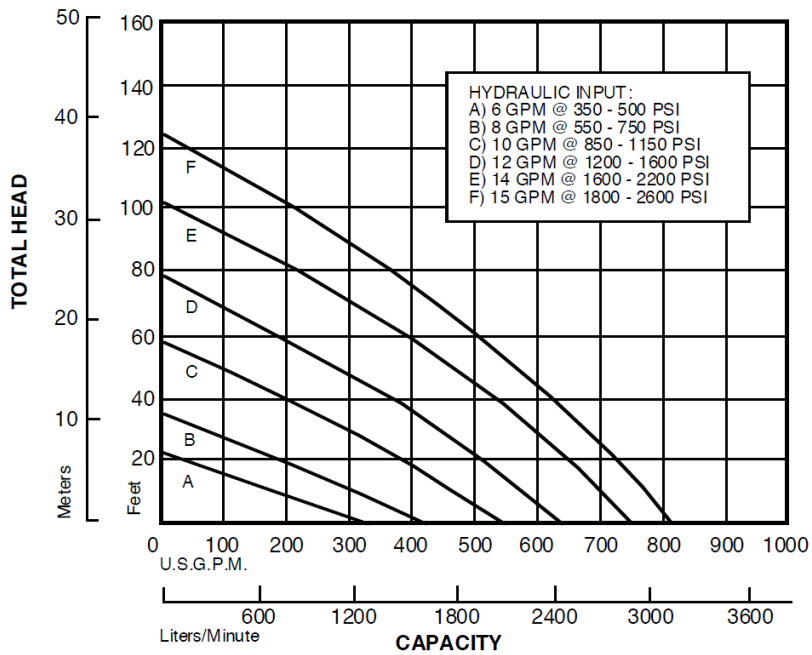

Curves are based on pumping water at 60°F. For performance curves other than shown above, consult factory.



167 Stock Street, Nesquehoning, PA 18240 Phone: 570-645-3779 Fax: 570-645-4061
 Website: www.hydra-tech.com E-Mail: htpump@hydra-tech.com